

CTC - RTM Room Thermostat

Installation and User Instructions

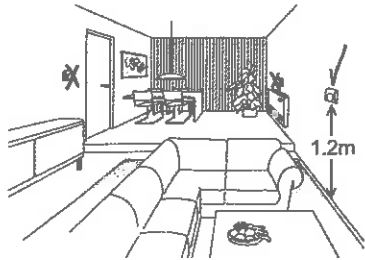

Care should be taken to mount the thermostat in a position that is not in direct sunlight, close to radiators or in draughts.



1 Cover removal

Caution: Isolate power supply and make safe before wiring the unit to prevent electric shock and equipment damage.

Installation should be carried out by a competent person.

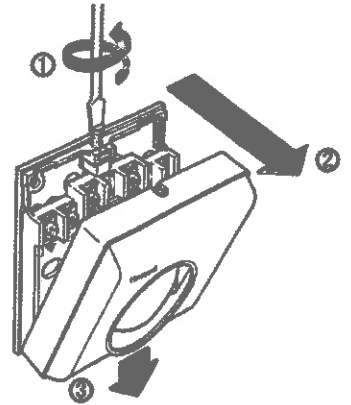

2 a Wall box mounting
Fixing holes spaced to suit BS4662

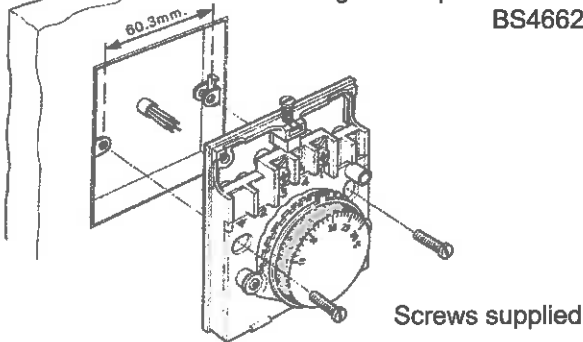

b Surface mounting
Use wall box fixing holes or alternatives shown

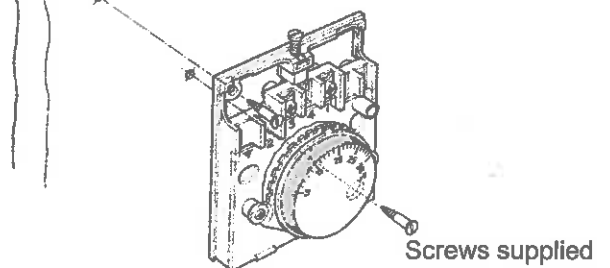

3 a Wall box wiring

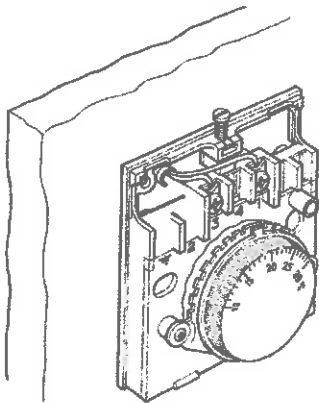

b Surface wiring

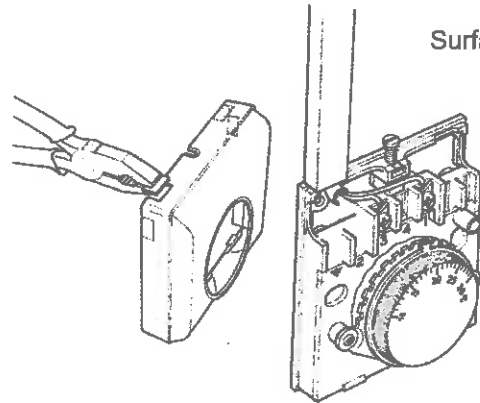

4 Wiring to terminals

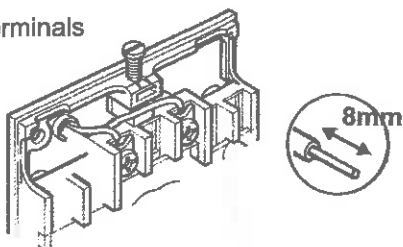

5 Completion

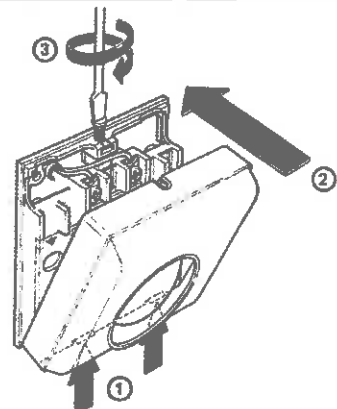

**All wiring must be in accordance with IEE Regulations.
This thermostat is for fixed wiring only.**

A switch, having contact separation of a least 3mm in all poles, must be incorporated in the fixed wiring as a means of disconnecting the supply.

The thermostat is a Class II (double insulated) device.

The heating system must be appropriately fused.
Most typical wet heating systems should be fused at 3 Amps.
Warm air and electrical systems may have a higher load.
Maximum fuse ratings is 16 Amps.

The thermostat has 4 knockouts on the cover for surface wiring installations. Care must be taken to use the knockouts so that the cable completely fills the knockout hole without leaving any gaps. Where used, mini-trunking must be fitted firmly against the thermostat cover in such a way as to leave no gap.

High current thermostat

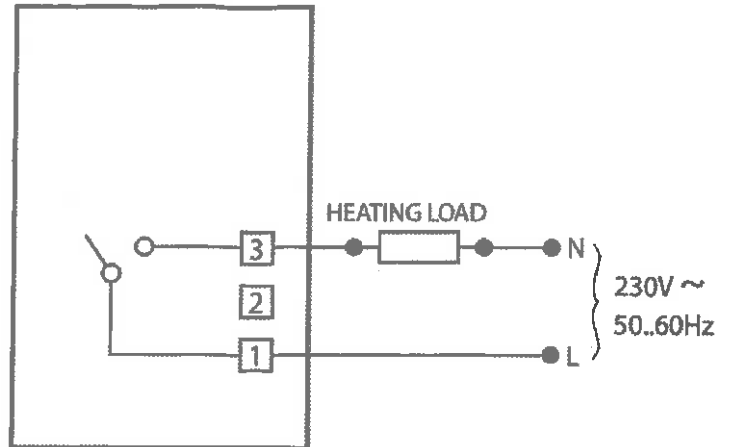

Terminal 3: 16 A Max
No anticipator connection required
Temp range: 10-30 deg C
Complies with: EN60730-1
EN60730-2.7
EMC 2004/108/EC
LVD 2006/95/EC

What is a room thermostat? ... an explanation for householders

A room thermostat simply switches the heating system on and off as necessary. It works by sensing the air temperature, switching on the heating when the air temperature falls below the thermostat setting and switching it off once this set temperature has been reached.

Turning a room thermostat to a higher setting will not make the room heat up any faster. How quickly the room heats up depends on the design of the heating system, for example, the size of the boiler and radiators.

Neither does the setting affect how quickly the room cools down. Turning a room thermostat to a lower setting will result in the room being controlled at a lower temperature, and saves energy.

The heating system will not work if a time switch or programmer has switched it off.

The way to set and use your room thermostat is to find the lowest temperature setting that you are comfortable with, and then leave it

alone to do its job. The best way to do this is to set the room thermostat to a low temperature – say 18°C and then turn it up by one degree each day until you are comfortable with the temperature. You won't have to adjust the thermostat further. Any adjustment above this setting will waste energy and cost you more money.

If your heating system is a boiler with radiators, there will usually be only one room thermostat to control the whole house. But you can have different temperatures in individual rooms by installing thermostatic radiator valves (TRV's) on individual radiators. If you don't have TRV's you should choose a temperature that is reasonable for the whole house. If you do have TRV's you can choose a slightly higher setting to make sure that even the coldest room is comfortable, then prevent any overheating in other rooms by adjusting the TRV's.

Room thermostats need a free flow of air to sense the temperature, so they must not be covered by curtains or blocked by furniture. Nearby electric fires, televisions, wall or table lamps may prevent the thermostat from working properly.



SERVICE AND WARRANTY

Your product is not user serviceable. PLEASE DO NOT TRY TO DISMANTLE THE UNIT. This product is guaranteed by your supplier for 2 years from the Date of Manufacture. If it should become defective, please contact your installer or supplier for a replacement unit.

CUSTOMER CARE POLICY

Due to our policy of continuous product improvement and development, the specifications in this guide may be subject to change without prior notice.